



## Efficient Flexible Protection for Commercial Spaces

### ROBUST PROTECTION

Secure, protective barrier against theft and intrusion.

### SLEEK EXECUTION

Narrow, 4 in. curtain profile fits in tight spaces easily.

### FLEXIBLE DURABILITY

Twin roller support with flexible lock, curve and finish options to meet security and aesthetic needs.

### STYLE DELIVERED

Seven (7) primary and 12 total infill styles to maximize security, visibility, and airflow.

### TURNKEY EFFICIENCY

With our optional Pro-Procket™, designers can quickly integrate and contractors can quickly install the QMi side-folding-grille.

# Features Summary

## CURTAIN

- Profile Line curtain constructed of panel modules linked together by continuous aluminum hinges (4 in. typ on center)
- Top, bottom, and other horizontal members extruded aluminum 6063-T-6.
- Specific curtain makeup depends on style
- Maximum height of 14 ft.

## TRACKS AND HINGES

- Curtain hung from overhead track 1-3/8 in. (W) x 1-3/4 in. (H)
- Full height hinges for durability and strength
- Track and hinges 6063-T6 extended aluminum
- Cold-rolled steel hanger rods (5/16 in. diameter) provide durability

## LOCKS

- Top and bottom lock posts, with drop bolts into floor or counter and header (at top)
- Free floating Intermediate posts located at all curves at recommended intervals of 10 ft. (floor) and 5 ft. (counter)
- IC lock cylinders (Medeco, Best, others) ILCO keyed-alike cylinders, or thumb turn factory fitted

## STACKING

- Stacking for Performance Line is approximately 2-1/4 in. per linear ft. of grille

## WARRANTY\*



# Options Summary

## STYLES

- Seven (7) primary and 12 overall styles available; select specifications include:
  - Q-Air: 14-gauge steel, with 3/16 in. diameter holes at 1/4 in. OC
  - Q-Clear: Polycarbonate panels 0.08 in. thickness optimized for clarity
  - Q-Solid: Extruded 6063-T6 aluminum panels

## PRO POCKET™ TURNKEY SYSTEM

- Optional integrated frame assembly to fit into stud wall, simplifying and speeding. UP installation
- Aluminum or steel pocket doors

## ADDITIONAL LOCKS

- Seven (7) different lock posts to meet application requirements

## CURVES

- 14 and 24 in. radius curves in 45° and 90° options
- Custom curves/radius available

## COLOR AND FINISH

- Clear (Silver) and Black Anodize (Type II, Class 2, 10µm)
- White (SH-Series Powder coat per AAMA 2603-13, DFT 60-110 µm)
- Custom in powder (above) or wet paint (H/S polyester 221T2602 DuraCoat wet paint, DFT 24-28 µm)

\*Applies to Commercial applications only and customers who follow Use and Care Guidelines

# System Details (Styles)

## Profile Line



Q-Clear  
(4 in.)

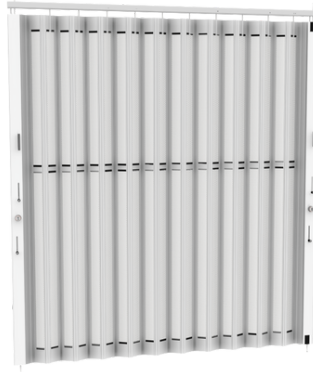

Q-Air  
(4 in.)



Q-Solid  
(4 in.)

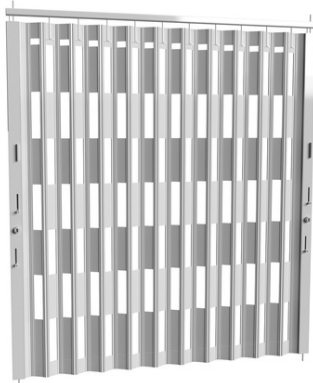

Q-Check  
(4 in.)

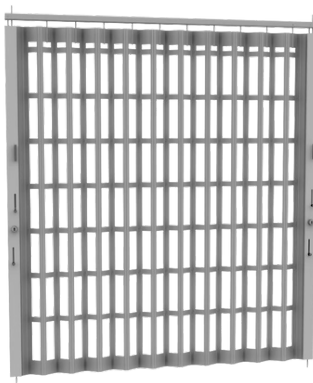

Q-Guard (Linear)  
(4 in.)



Q-Guard (Offset)  
(4 in.)



Q-Guard (Staggard)  
(4 in.)

### STYLE DETAILS

- Seven (7) primary styles, with 12 total
- Q-Check available in 9 and 12 in. vertical pattern, either open or with polycarbonate inserts
- Q-Guard Offset and Staggard available either open or with polycarbonate inserts

# System Details (Curtain, Ref)

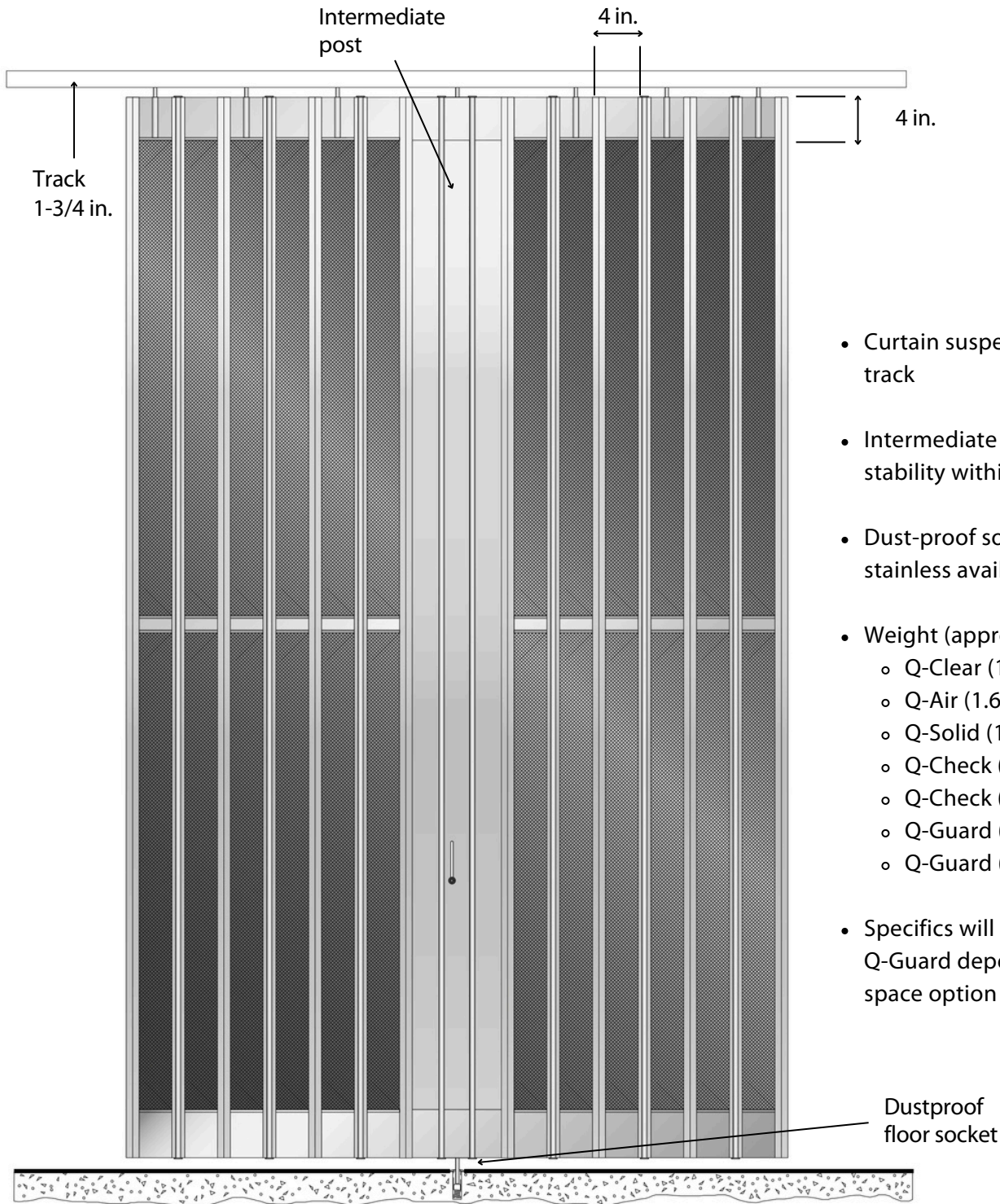

- Curtain suspended from 1-3/4 in. track
- Intermediate posts provide locking stability within curtain
- Dust-proof sockets for floors, stainless available for counters
- Weight (approximate lbs. per sq. ft.)
  - Q-Clear (1.5)
  - Q-Air (1.6)
  - Q-Solid (1.9)
  - Q-Check (open, ref) (1.7)
  - Q-Check (poly, ref) (1.7)
  - Q-Guard (open, ref) (1.6)
  - Q-Guard (poly-ref) (1.6)
- Specifics will vary for Q-Check and Q-Guard depending on vertical space option chosen.

# System Details (Section, Pocket, and Track)

## Section Panel

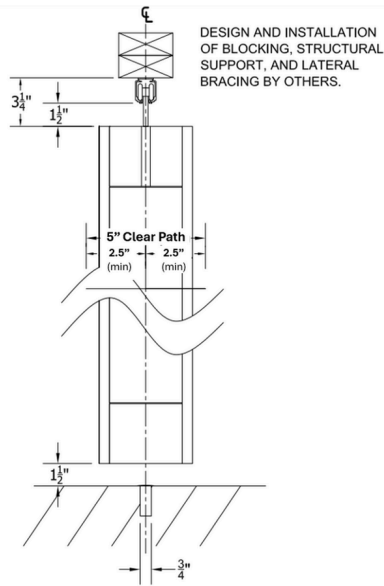

- 5 in. minimum clear path required
- Design and installation of blocking, structural support, and lateral bracing by others

- Reference stacking for profile line is 2-1/4 in. per linear ft. of grille
- Curves into pocket may vary the minimum pocket width required
- Closet and door by other

## Pocket

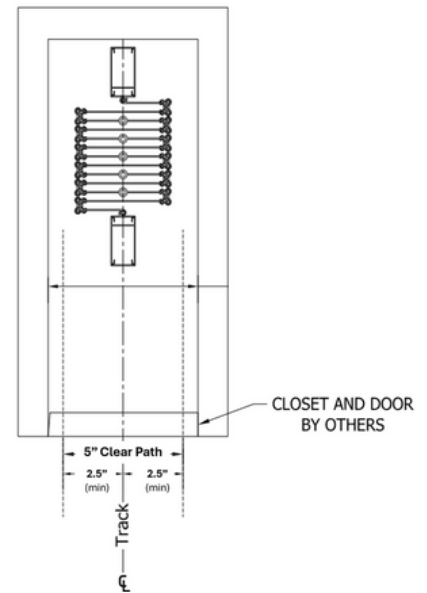

## Track

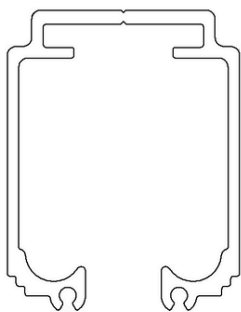

1-3/8 in. (W) x 1-3/4 in. (H)

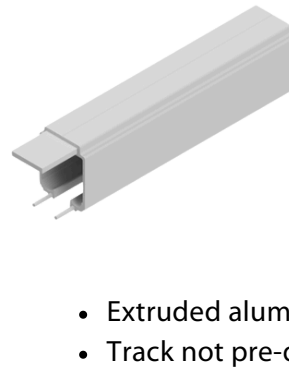

- Extruded aluminum track strong but lightweight
- Track not pre-drilled for field

# Option Details (Posts and Layouts)

## Posts

### WALL STRIKE (1)

Securely attach your grille to a wall strike, ensuring it is firmly anchored to the wall. (2x backing by others required) Use the top cylinder to engage the hook lock between the lead post and the wall strike. For added security, utilize manual, spring-loaded knobs with a lower cylinder release for shoot bolting to the floor and track.

### END POST (2)

Enjoy the benefit of manual, spring-loaded knobs with cylinder release for shoot-bolting directly to both the floor and track.

### MIDDLE POST (3)

Used in middle of a span, they ensure stability in extended grille setups with manual, spring-loaded knobs and cylinder release for secure shoot bolting directly to the floor.

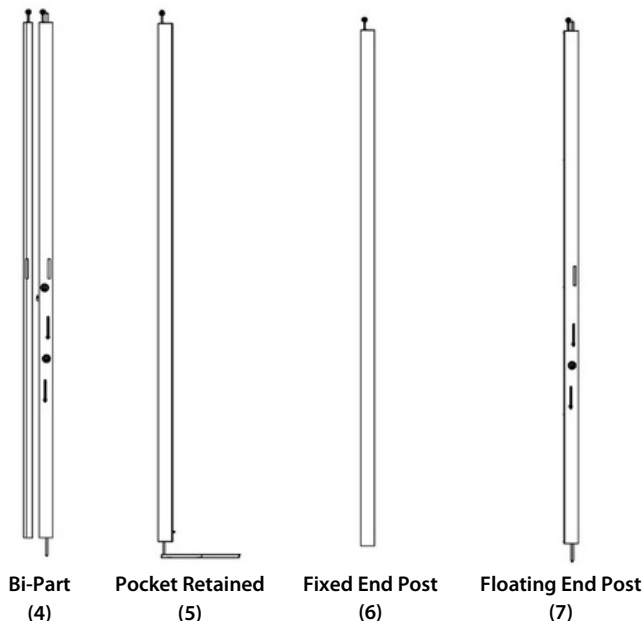
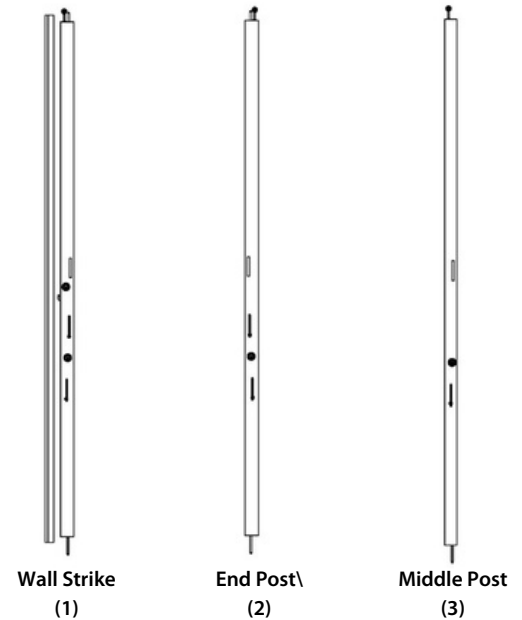

### BI-PART (4)

Securely latches grille sections at the middle connection location using a top cylinder to operate the hook lock. Manual, spring-loaded knobs with a lower cylinder release enable secure shoot bolting to both the floor and track,

### POCKET RETAINED POST (5)

Requires no locks and stops efficiently at both the floor and track within the closet.

### FIXED END POST (6)

Even without locks, the Fixed End Post ensures your grille's end remains firmly anchored to the wall (2x backing by others required)

### FLOATING END POST (7)

Secure bolting anywhere along curtain. Combines a sleek design with practicality, using manual, spring-loaded knobs and a cylinder release for secure bolting to the floor and track on the secured side while remaining discreet on the public side.

# Option Details (Post and Layouts Continued)

## Standard Bends

- 45° and 90° bends standard
- 14 or 24 in. radius standard
- Custom shapes available (lead time)

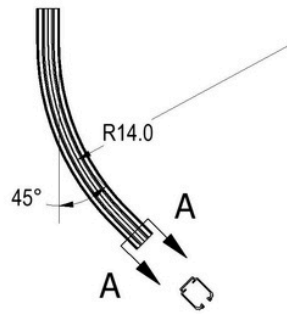

45° - 14 in.

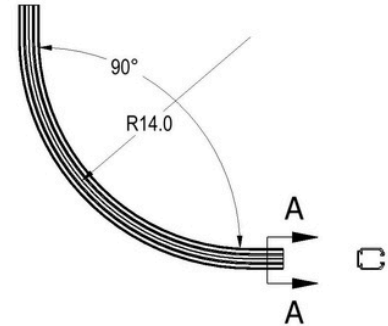

90° - 14 in.

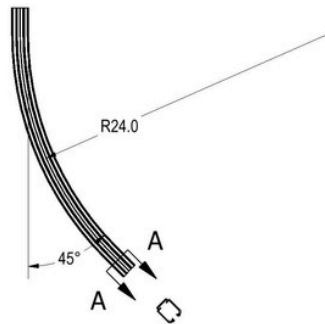

45° - 24 in.

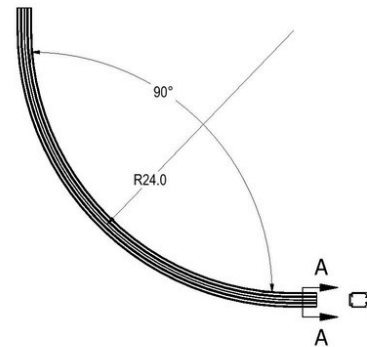

90° - 24 in.

## Sample Layouts

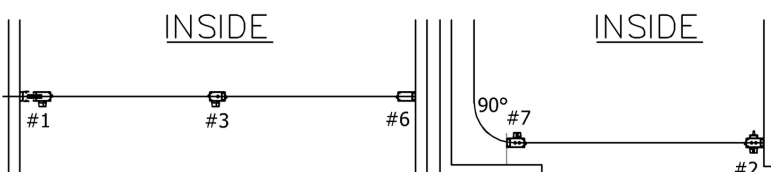
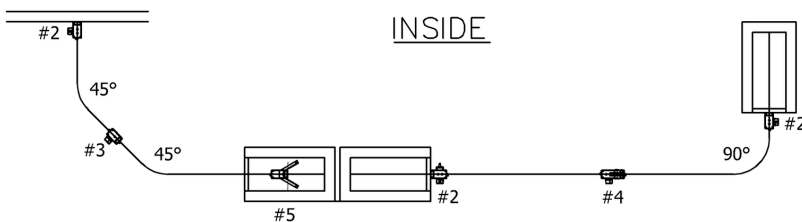

- All post configurations can be used throughout curtain depending upon applications need
- Contact QMi Application Engineering for questions

# System Options (Pro Pocket™ and Colors)

## Pro-Pocket™ Turnkey System

QMi Profile Line Side-Folding Grilles are designed for efficiency, resilience, and simplicity. With our optional Pro-Pocket™, architects can easily spec in the turnkey solution, designed to fit into a standard commodity stud wall. Pocket made of carbon steel.

Pro-Pocket™ products are shipped as an integrated assembly, ready to quickly field install. Anodized aluminum or steel pocket doors with handles included. Efficient security - delivered

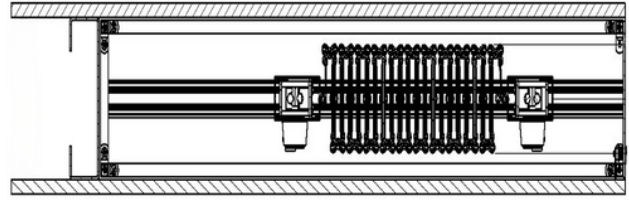

Pro-Pocket™ Closed Stack  
(As Shipped)

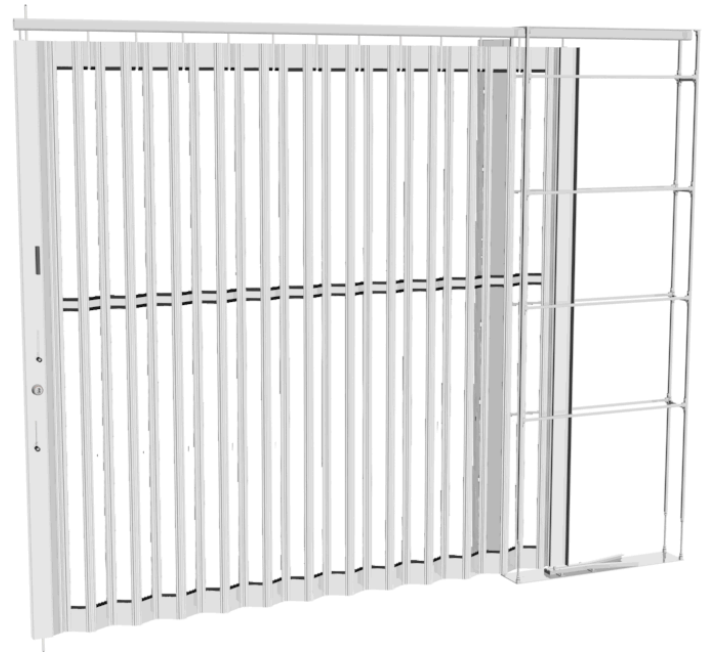

Pro-Pocket™ Extended  
(In Use)

## Colors and Finish



Clear Anodized  
(Silver)

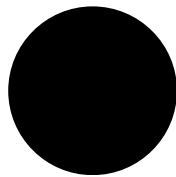

Black  
Anodized



White



Custom

Powder coat and wet paint options for both standard and custom colors are available. Contact your QMi Sales or Project Support Representative for pricing and lead times on custom color options.



# Mounting Details

## Threaded Rod

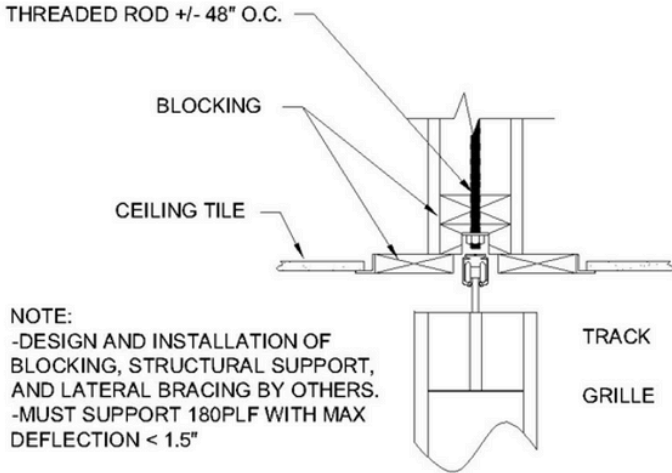

System designed for above ceiling installation with blocking and a threaded rod

## Above Ceiling (Flush)

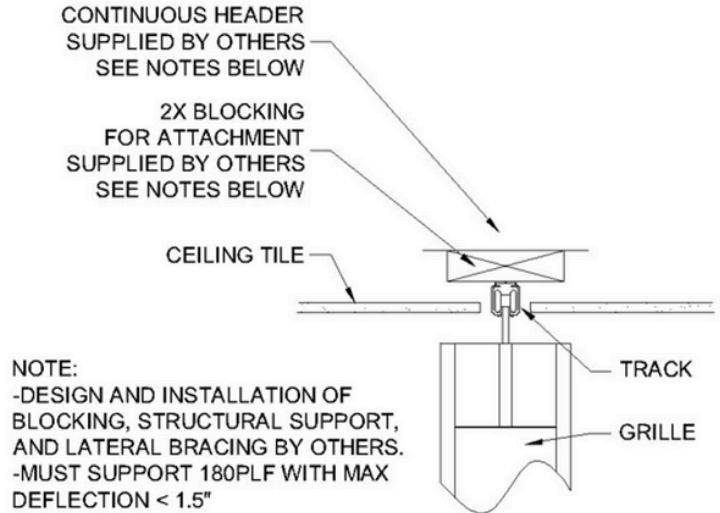

System can be flush mounted to existing or provided blocking, flush to ceiling

## Above Ceiling (Proud)

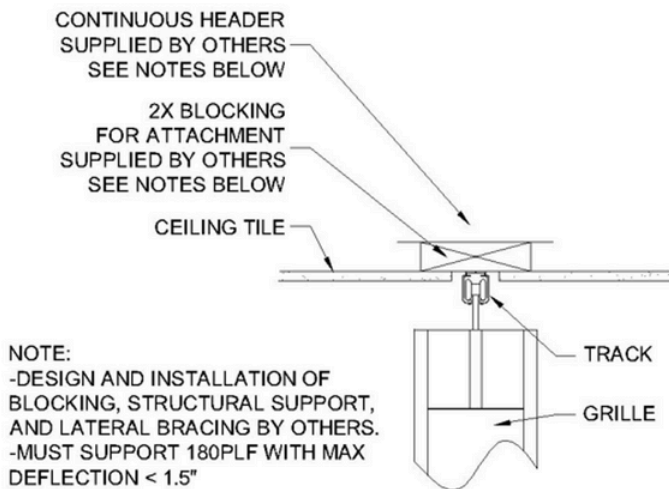

System can be mounted to existing or provided blocking, proud to ceiling

**Wide range of mounting options available, Contact QMi Applications Engineering for more details.**